



SGM595 Sensor



- For LPG
- Microprocessor control
- 4 - 20 mA signal
- IP55 enclosure
- Sintered head
- Catalytic sensor technology
- Sensor active indicator Designed to
- EN50194
- Auto calibration
- 2 Year Warranty - 3 years by registering this product online www.duomo.co.uk

Application

Duomo is recognised within the gas industry for providing a comprehensive range of low cost, high reliability gas detection for many applications. We have installed and commissioned natural gas and carbon monoxide sensors in applications such as boiler rooms, kitchens, car parks, aircraft hangers, factories and shopping centres. The SGM595 is the gas sensor used with the complete range of Duomo detector panels. All Duomo products are manufactured to meet relevant European Normatives and proposals for explosive and toxic gases.

Operation

When the SGM595 senses the presence of gas it sends a 4 - 20mA signal to the detector proportional to the level of gas. The detector then operates a pre-alarm relay - used for remote sirens or visual indicators if the level of gas continues to rise then the main alarm relay is activated to break the electrical supply to a safety shut off valve, and is fixed at 20% LEL of LPG.

Features

The SGM595 is controlled by a microprocessor. This conducts both self diagnostics and automatically calibrates the sensor when ambient conditions vary, thus avoiding false alarms. A hand-held datalogger can be connected to the SGM595 and information about the sensor can be read and printed out i.e.:

- the serial number
- the sensor condition
- how many times the sensor has been powered up
- how many alarms have occurred
- how many days of anticipated life remain
- how many auto adjusts have been made and
- the preset calibration state

CAUTION! Carefully read the following instructions prior to installation of this device. Always keep this pamphlet for future reference. Ensure that the gas detection system is wired correctly and is only used for the purpose for which it is intended.



DO NOT TEST THIS SENSOR WITH ANYTHING OTHER THAN CALIBRATED DUOMO LPG TEST GAS. Concentrations above this will damage the sensor and shorten sensor life.

Overall Dimensions

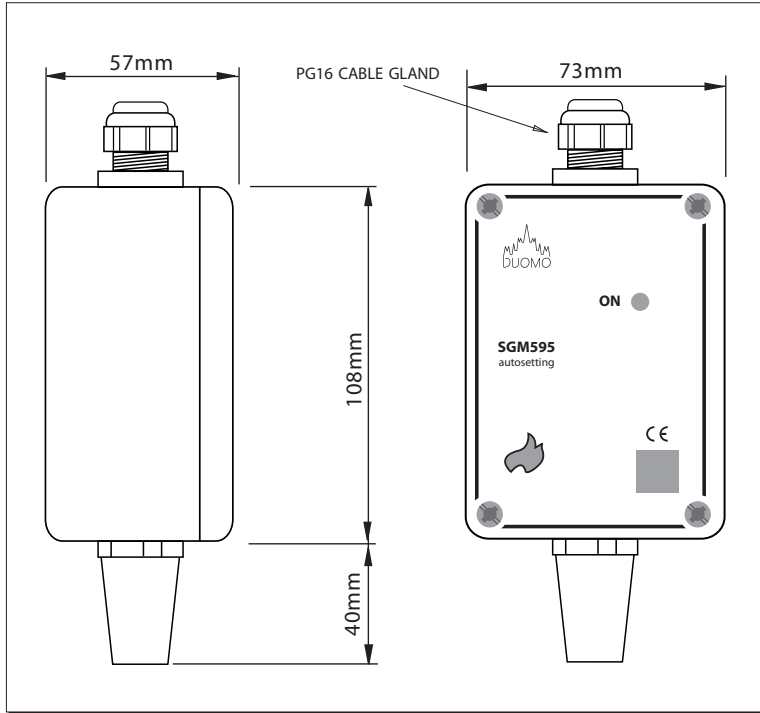
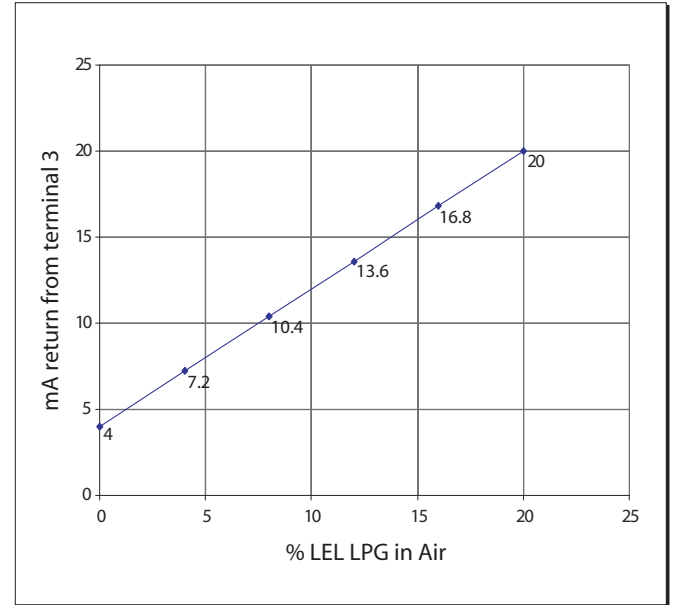

Diagram of Linear Detection



Positioning Sensors

The SGM595 sensor should be mounted in accordance with certain considerations. Do not position next to burners, heaters or ovens where temperatures above the room ambient may be experienced. It is, if possible, better to mount the sensors on the opposite wall. This is, of course, dependant on the size of the protected area.

LPG is heavier than air and will therefore drop, meaning the SGM595 sensor should be mounted 300mm from the floor of the protected area.

If you require assistance regarding locating sensors please call our Droitwich factory on (01905) 797989 or fax a drawing of your application to (01905) 774296 and we will advise accordingly.

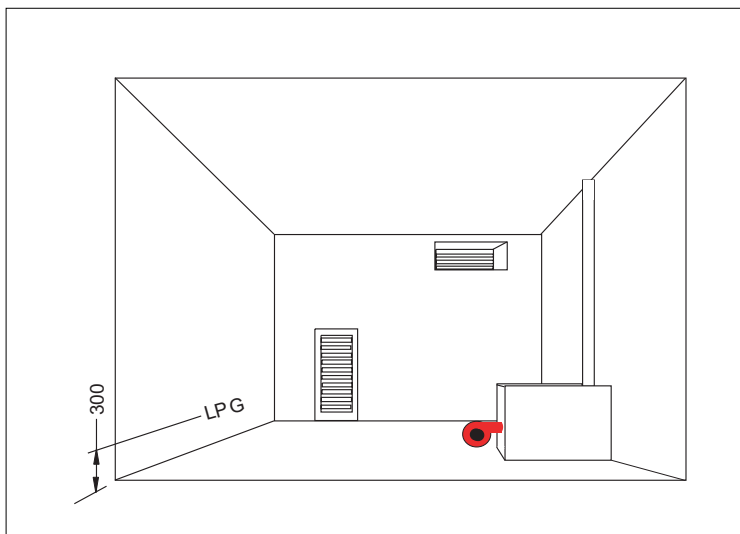

Installing A Sensor

The sensors must be mounted as shown below with the sintered head pointing vertically down.

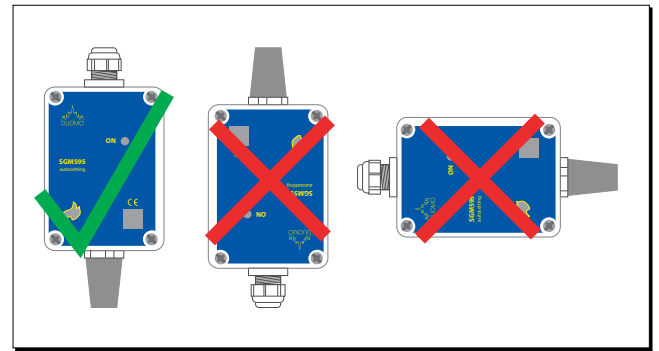

Important Notes

The installation of this gas detector does not release the user from observing all the regulations concerning the characteristics, installation and the use of gas appliances; the ventilation of the environment and the elimination of combustion products in accordance with local recommendations, regulations and byelaws.

For any damage caused to people, property or animals resulting from incorrect connection, installation or application of this gas detector Duomo will not be held responsible or liable.

Replacing Sensors

When replacing sensors **NEVER** separate a sensing head from the PCB. The sensor has been calibrated using only that particular board and therefore will not function correctly with any other.

Typical Wiring Schematic for GS300M & SGM595

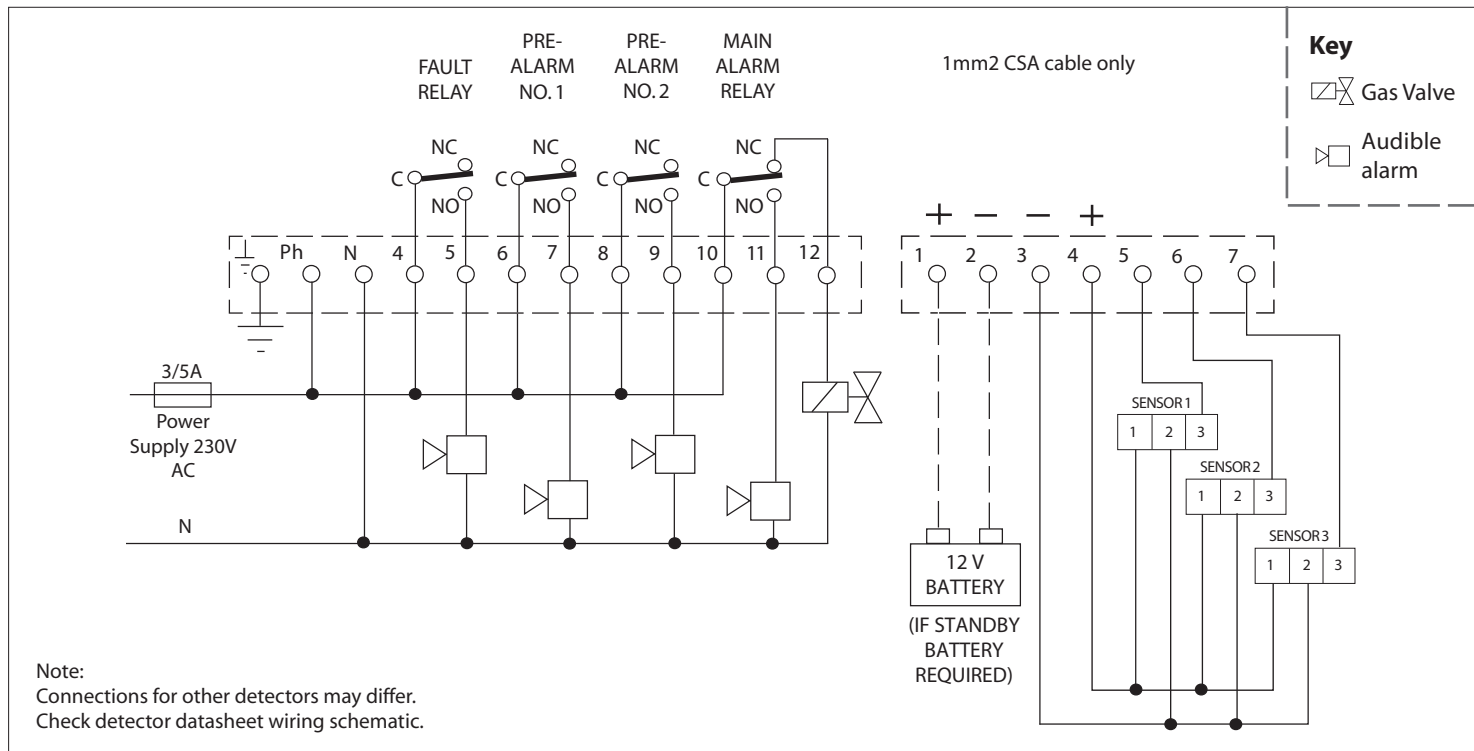

Electrical Installation

This sensor is designed to be connected directly to Duomo gas detector controls (BX150, GS100M, GS300M and BX444M). These are safety devices and are designed to give audible alarms and automatically provide latched electrical isolation of associated gas safety shut off valves. The sensor can be located up to 100m from the gas detector. Cable size should be 1mm² csa. If the sensor cables are run separately in specific conduit it is not essential to use screened cable but if the cables are routed through conduit or trunking containing other wiring the use of screened cable is advisable. The wiring should be performed by a qualified person in accordance with current regulations. The plug in terminal rail makes installation easy and quick.

Check wiring before powering up the system.

In Case Of Alarm

- Extinguish any naked flames.
- Do not switch lights or electrical devices on or off.
- Open all windows and doors to increase ventilation.
- If the audible alarm changes from continuous to intermittent the levels of gas have dropped. A responsible, qualified person is now safe to find the cause of the alarm.
- If the alarm sound remains constant, and the cause is not evident or possible to eliminate turn off the emergency isolation valves to the area and contact your gas provider emergency line. They will advice accordingly.

SGM595 PCB Layout

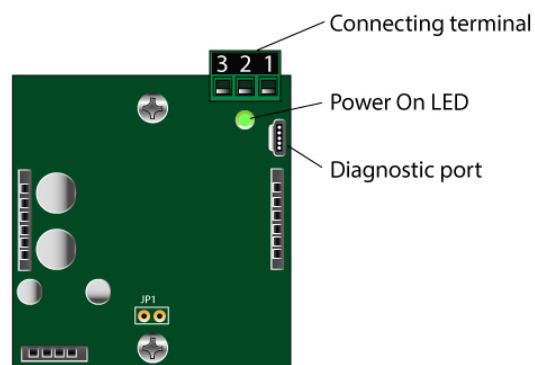

Technical Specifications

Power supply: 12-24V DC +/- 10% from detector
 Electrical input: 80mA @ 13.8V
 External protection rating: IP55
 Working temperature: -10°C to 40°C
 Sensor type: Nemoto catalytic
 Maximum distance from sensor to detector: 100m
 CE certification: No. 96125
 Detection: 4 to 20mA (5% to 20% LEL)
 Calibrated using: Duomo test gases
 Interconnecting cable size: 1mm csa
 Material used for housing: ABS self-extinguishing plastic.
 Dimensions: 76 x 160 x 58

